

Write your name here

Surname

Other names

**Pearson Edexcel
International GCSE**

Centre Number

--	--	--	--	--

Candidate Number

--	--	--	--

Mathematics A

Paper 2FR



Foundation Tier

Tuesday 17 January 2017 – Morning
Time: 2 hours

Paper Reference

4MA0/2FR

You must have:

Ruler graduated in centimetres and millimetres, protractor, compasses, pen, HB pencil, eraser, calculator. Tracing paper may be used.

Total Marks

--

Instructions

- Use **black** ink or ball-point pen.
- **Fill in the boxes** at the top of this page with your name, centre number and candidate number.
- Answer **all** questions.
- Without sufficient working, correct answers may be awarded no marks.
- Answer the questions in the spaces provided
– *there may be more space than you need.*
- **Calculators may be used.**
- You must **NOT** write anything on the formulae page.
Anything you write on the formulae page will gain NO credit.

Information

- The total mark for this paper is 100.
- The marks for **each** question are shown in brackets
– *use this as a guide as to how much time to spend on each question.*

Advice

- Read each question carefully before you start to answer it.
- Check your answers if you have time at the end.

Turn over ►

P48404A

©2017 Pearson Education Ltd.

2/1/17



Pearson

International GCSE MATHEMATICS
FORMULAE SHEET – FOUNDATION TIER

Pythagoras' Theorem
 $a^2 + b^2 = c^2$

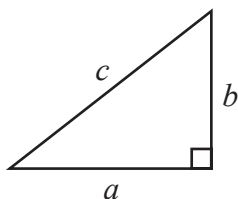

Area of a trapezium = $\frac{1}{2}(a + b)h$

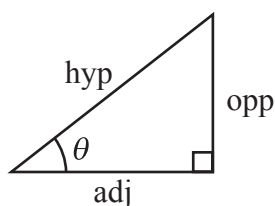
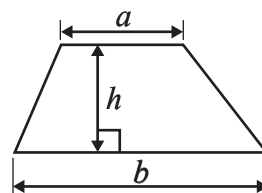

adj = hyp \times cos θ
 opp = hyp \times sin θ
 opp = adj \times tan θ

Volume of prism = area of cross section \times length

or $\sin \theta = \frac{\text{opp}}{\text{hyp}}$

$\cos \theta = \frac{\text{adj}}{\text{hyp}}$

$\tan \theta = \frac{\text{opp}}{\text{adj}}$

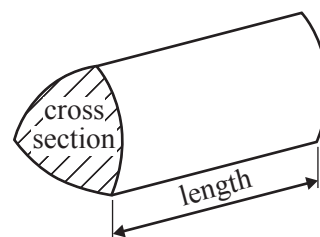

Circumference of circle = $2\pi r$

Area of circle = πr^2

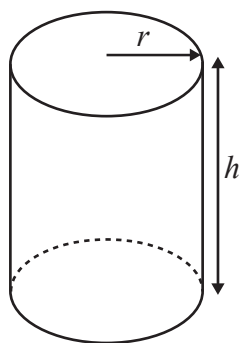

Volume of cylinder = $\pi r^2 h$

Curved surface area of cylinder = $2\pi r h$

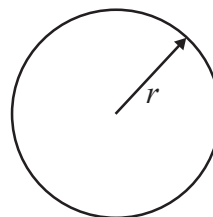

DO NOT WRITE IN THIS AREA

DO NOT WRITE IN THIS AREA

DO NOT WRITE IN THIS AREA



Answer ALL TWENTY FOUR questions.

Write your answers in the spaces provided.

You must write down all the stages in your working.

- 1 The table shows the heights of six mountains.

Mountain	Height (metres)
Aconcagua	6959
Ben Nevis	1344
Kilimanjaro	5895
Bogong	1986
Everest	8848
Steele	5073

- (a) What is the smallest odd number in the table?

.....
(1)

- (b) Write down the value of the 3 in the number 1344

.....
(1)

The height of Everest is greater than the height of Aconcagua.

- (c) How many metres greater?

..... metres
(1)

(Total for Question 1 is 3 marks)

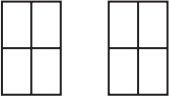
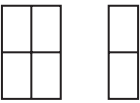
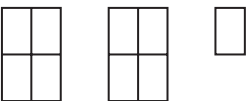

- 2 The pictogram gives information about the number of books Matilda borrowed from a library in January, in February and in March.

January	
February	
March	
April	

 represents 8 books

- (a) How many books did Matilda borrow from the library in January?

.....
(1)

- (b) How many books did Matilda borrow from the library in February?

.....
(1)

In April, Matilda borrowed 4 more books than she borrowed in March.

- (c) Show this information on the pictogram.

(2)

(Total for Question 2 is 4 marks)



DO NOT WRITE IN THIS AREA

DO NOT WRITE IN THIS AREA

DO NOT WRITE IN THIS AREA

3 The diagram shows a shape drawn on a centimetre grid.

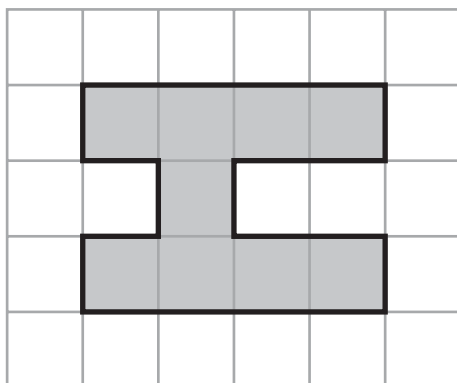

(a) (i) Find the area of the shape.

..... cm²

(ii) Find the perimeter of the shape.

..... cm

(iii) On the grid, draw the line of symmetry of the shape.

(3)

Here is a different shape.

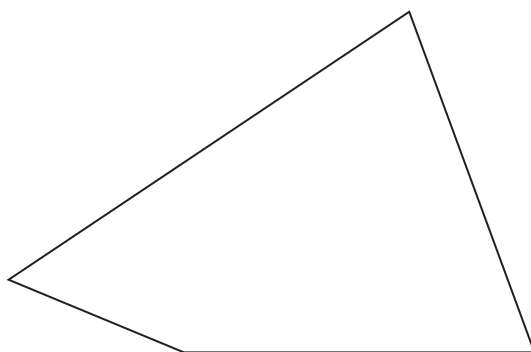

(b) On this shape, mark an obtuse angle.
Label your angle *O*

(1)

(Total for Question 3 is 4 marks)



- 4 (a) Write down the number that is exactly halfway between 8.6 and 8.7

.....
(1)



- (b) Write down the number on the scale marked with an arrow.

.....
(1)



- (c) (i) On this scale, mark with an arrow (\downarrow) the number 7.235
(ii) Write 7.235 to the nearest whole number.

.....
(2)

(Total for Question 4 is 4 marks)



DO NOT WRITE IN THIS AREA

DO NOT WRITE IN THIS AREA

DO NOT WRITE IN THIS AREA

5 The diagram shows a 5-sided polygon $ABCDE$ drawn on a centimetre grid.

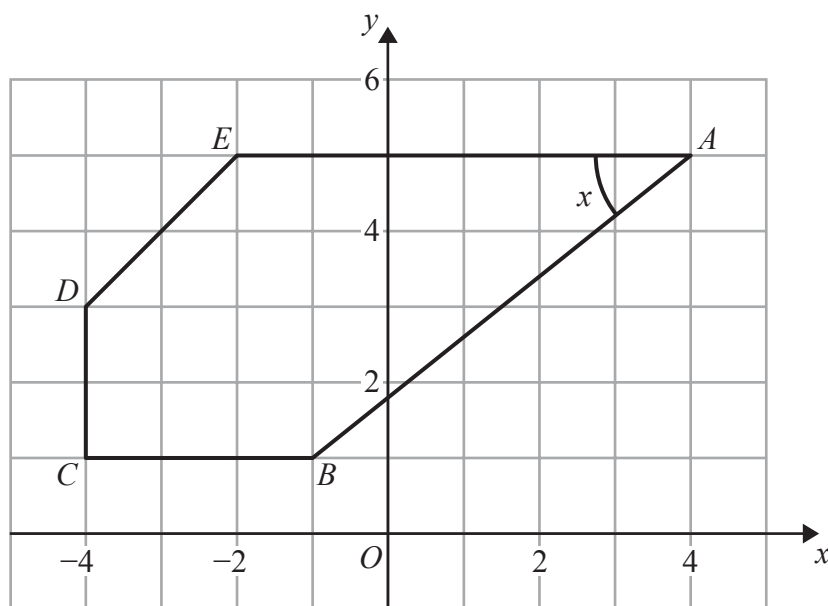

(a) Write down the coordinates of the point A .

(.....,)
(1)

(b) Write down the coordinates of the point C .

(.....,)
(1)

(c) Write down the mathematical name for a 5-sided polygon.

.....
(1)

(d) Measure the length of the line AB .
Give your answer in centimetres to 1 decimal place.

..... cm
(1)

(e) Measure the size of the angle marked x .

.....
(1)

(Total for Question 5 is 5 marks)



6 Here is a sequence of patterns made from sticks.



Pattern number 1



Pattern number 2



Pattern number 3

(a) Complete the table.

Pattern number	1	2	3	4
Number of sticks	4	7	10	

(1)

(b) Explain how you worked out your answer.

(1)

(c) How many sticks are needed to make Pattern number 12?

(2)

(d) Work out the Pattern number of the pattern made from exactly 67 sticks.

(2)

(Total for Question 6 is 6 marks)



DO NOT WRITE IN THIS AREA

DO NOT WRITE IN THIS AREA

DO NOT WRITE IN THIS AREA

7 The table shows information about average temperatures for five months in Beijing.

Month	Average temperature ($^{\circ}\text{C}$)
October	13
November	5
December	-2
January	-4
February	-1

(a) Which of these months has the lowest average temperature?

.....
(1)

(b) Work out the difference between the average temperature in October and the average temperature in December.

..... $^{\circ}\text{C}$
(2)

The average temperature in June is 28°C higher than in January.

(c) Work out the average temperature in June.

..... $^{\circ}\text{C}$
(2)

(Total for Question 7 is 5 marks)



8 Here are the distances cycled, in km, on the first 6 days of the 2015 Tour de France cycle race.

Day	1	2	3	4	5	6
Distance (km)	14	166	160	224	190	192

(a) Work out the range of these distances.

..... km
(1)

(b) Work out the median distance.

..... km
(2)

Michel says,

“The median is a better average to use for these 6 distances than the mean.”

(c) Explain why Michel is right.

.....
.....
(1)

(Total for Question 8 is 4 marks)



9

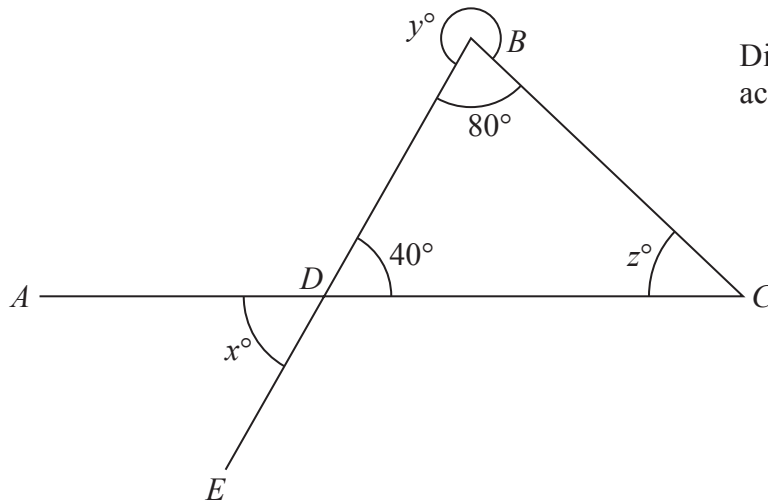

Diagram **NOT**
accurately drawn

ADC is a straight line.
 BDE is a straight line.

Angle $DBC = 80^\circ$
Angle $BDC = 40^\circ$

(a) Write down the value of x .

$$x = \dots\dots\dots (1)$$

(b) Work out the value of y .

$$y = \dots\dots\dots (1)$$

(c) Work out the value of z .

$$z = \dots\dots\dots (2)$$

(Total for Question 9 is 4 marks)

DO NOT WRITE IN THIS AREA

DO NOT WRITE IN THIS AREA

DO NOT WRITE IN THIS AREA



- 10 Alison buys 6 plants.
The plants cost £2.96 each.
She pays with a £20 note.

Work out how much change Alison should get.

£.....

(Total for Question 10 is 3 marks)

- 11 (a) Write 23% as a fraction.

.....
(1)

Here are 5 numbers.

$\frac{5}{9}$ 0.59 $\frac{8}{15}$ 61% $\frac{3}{5}$

- (b) Write these numbers in order of size.
Start with the smallest number.

.....
(3)

(Total for Question 11 is 4 marks)



DO NOT WRITE IN THIS AREA

DO NOT WRITE IN THIS AREA

DO NOT WRITE IN THIS AREA

12 (a) Simplify $6e + 8f - 2e + 3f$

.....
(2)

(b) Solve $7x + 11 = 14$

$x =$
(2)

(c) Expand $3(4p + 5)$

.....
(1)

(d) Factorise $6r + 14$

.....
(1)

(Total for Question 12 is 6 marks)



13 (a) Find the cube number that is between 650 and 750

.....
(1)

(b) Find the prime number that is between 85 and 95

.....
(1)

(c) (i) Find the cube root of 72

Write down all the figures on your calculator display.

(ii) Write your answer to part (i) correct to 2 significant figures.

.....
(2)

(Total for Question 13 is 4 marks)



14

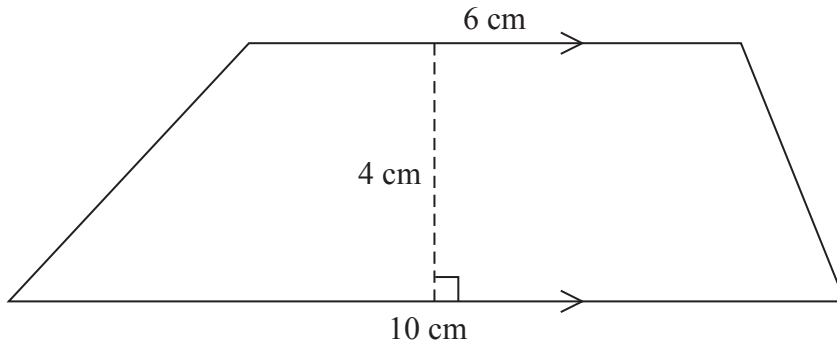

Diagram **NOT** accurately drawn

Work out the area of this trapezium.

..... cm²

(Total for Question 14 is 2 marks)

DO NOT WRITE IN THIS AREA

DO NOT WRITE IN THIS AREA

DO NOT WRITE IN THIS AREA



15 Cartons are packed into a box.

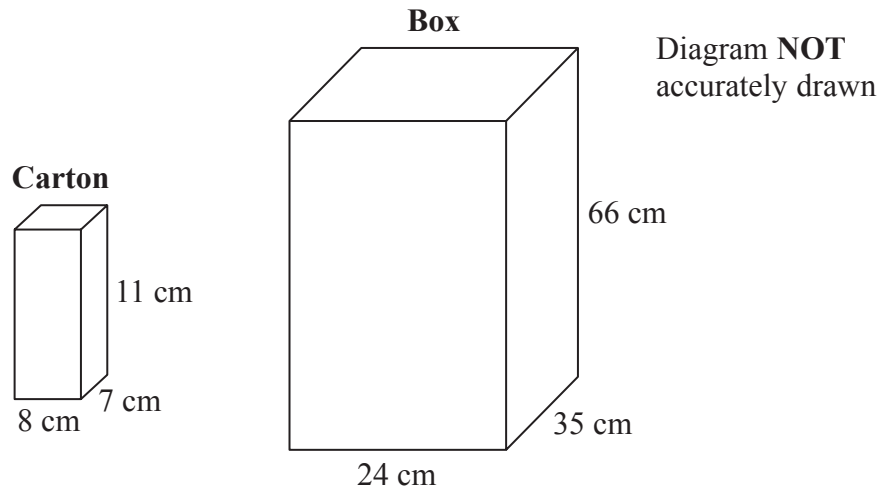

Each carton is 8 cm by 7 cm by 11 cm.
The box is 24 cm by 35 cm by 66 cm.

The box is completely filled with cartons.

Work out the number of cartons in the box.

(Total for Question 15 is 3 marks)

DO NOT WRITE IN THIS AREA

DO NOT WRITE IN THIS AREA

DO NOT WRITE IN THIS AREA



DO NOT WRITE IN THIS AREA

DO NOT WRITE IN THIS AREA

DO NOT WRITE IN THIS AREA

16 Here is a list of ingredients for making 24 Rocky Road Crunchy Bars.

Rocky Road Crunchy Bars	
Ingredients for 24 bars	
125 grams	butter
300 grams	chocolate
3 tablespoons	syrup
200 grams	biscuits
100 grams	marshmallows
2 teaspoons	icing sugar

Silvester wants to make 30 Rocky Road Crunchy Bars.

(a) Work out the amount of marshmallows he needs.

..... grams
(2)

Nigella makes some Rocky Road Crunchy Bars.
She uses 850 grams of chocolate.

(b) Work out the number of Rocky Road Crunchy Bars she makes.

.....
(2)

(Total for Question 16 is 4 marks)



17 Here is a biased 4-sided spinner.

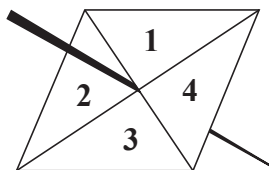

The spinner is spun.

The table shows the probability that the spinner lands on 1 and the probability that it lands on 2

Number	1	2	3	4
Probability	0.15	0.4		

(a) Work out the probability that the spinner will **not** land on 1

.....
(2)

(b) Work out the probability that the spinner will land on 1 or on 2

.....
(1)

The probability that the spinner will land on 3 is twice the probability that the spinner will land on 4

(c) Work out the probability that the spinner will land on 3

.....
(2)

Daljit is going to spin the spinner 160 times.

(d) Work out an estimate for the number of times the spinner will land on 2

.....
(2)

(Total for Question 17 is 7 marks)



DO NOT WRITE IN THIS AREA

DO NOT WRITE IN THIS AREA

DO NOT WRITE IN THIS AREA

18 $\mathcal{E} = \{1, 2, 3, 4, 5, 6, 7, 8, 9, 10\}$
 $A = \{2, 3, 5, 7\}$
 $B = \{1, 3, 5, 7, 9\}$

List the members of the set

(i) $A \cap B$

.....

(ii) $A \cup B$

.....

(Total for Question 18 is 2 marks)



19 The diagram shows a rectangle and a circle.

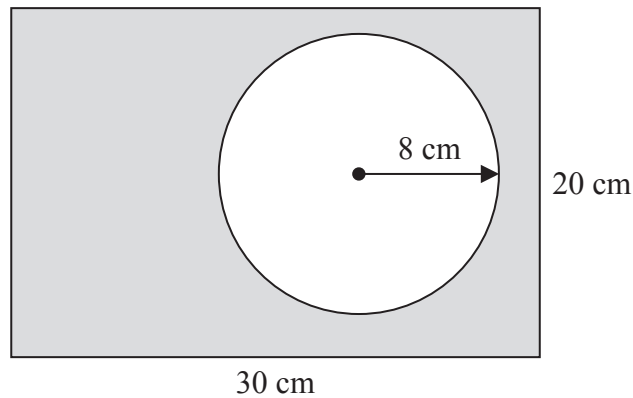

Diagram **NOT** accurately drawn

The rectangle has length 30 cm and width 20 cm.
The circle has radius 8 cm.

Work out the area of the shaded region.
Give your answer correct to 3 significant figures.

..... cm²

(Total for Question 19 is 4 marks)

20 In a sale, normal prices are reduced by 35%
The normal price of a bed is \$1200
Work out the sale price of the bed.

\$

(Total for Question 20 is 3 marks)



21

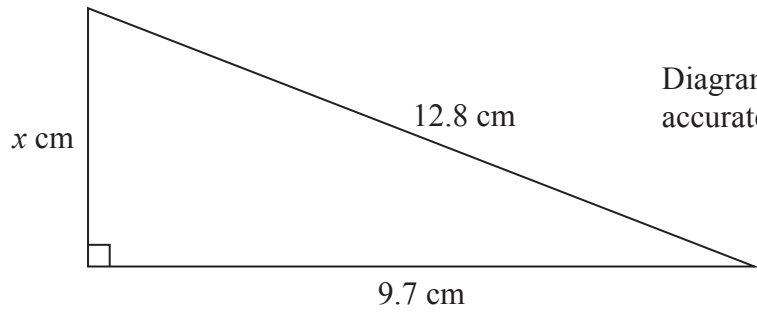

Diagram **NOT**
accurately drawn

Work out the value of x .
Give your answer correct to 3 significant figures.

(Total for Question 21 is 3 marks)

DO NOT WRITE IN THIS AREA

DO NOT WRITE IN THIS AREA

DO NOT WRITE IN THIS AREA



22 (a) Work out the value of $y^2 - 3y$ when $y = -5$

(2)

(b) Simplify $\frac{w^5 w^8}{w^4}$

(2)

(c) Write down the inequality shown on the number line.

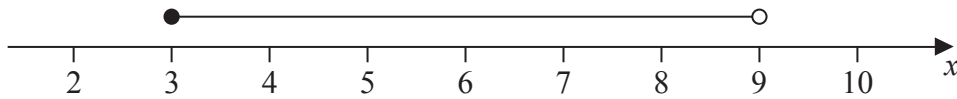

(2)

(Total for Question 22 is 6 marks)



DO NOT WRITE IN THIS AREA

DO NOT WRITE IN THIS AREA

DO NOT WRITE IN THIS AREA

23 The diagram shows a parallelogram $ABCD$.

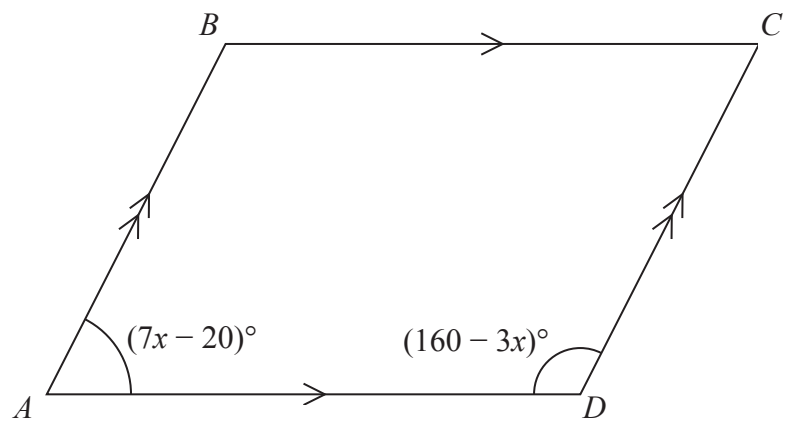

Diagram **NOT** accurately drawn

Angle $BAD = (7x - 20)^\circ$
Angle $ADC = (160 - 3x)^\circ$

Work out the value of x .
Show clear algebraic working.

$x = \dots\dots\dots$

(Total for Question 23 is 3 marks)



- 24 The diagram shows the positions of two towns, A and B .

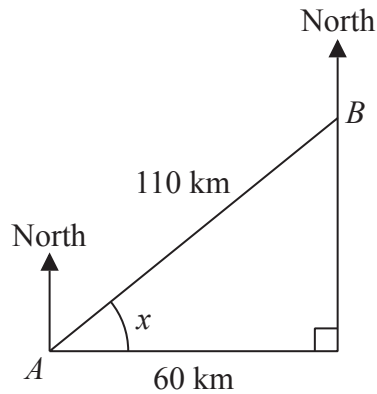

Diagram **NOT**
accurately drawn

The distance from A to B is 110 km.
 B is 60 km east of A .

- (a) Work out the size of angle x .
Give your answer correct to 1 decimal place.

.....
(3)

- (b) Work out the bearing of B from A .
Give your answer correct to the nearest degree.

.....
(2)

The distance from A to B is 110 km correct to 2 significant figures.

- (c) (i) Write down the lower bound for the distance from A to B .

..... km

- (ii) Write down the upper bound for the distance from A to B .

..... km

(2)

(Total for Question 24 is 7 marks)

TOTAL FOR PAPER IS 100 MARKS

